

## ECM8™ Electrochemical Multiplexer



The Gamry ECM8 Electrochemical Multiplexer is designed for electrochemical applications. The ECM8 Multiplexer connects up to eight electrochemical cells to one Gamry Potentiostat/Galvanostat/ZRA. This converts a single Potentiostat into a powerful instrument capable of automated sequential electrochemical experiments. Applications for the ECM8 include corrosion inhibitor testing, EIS

evaluation of paints and coatings, monitoring of field probes for corrosion tests, chemical sensor development, specialty battery testing, and many more.

The ECM8 works with Gamry's PCI4/300, PCI4/750, and FAS2 Potentiostats, as well as the earlier PC4 Potentiostats. Software control for the ECM8 is integrated into selected Gamry application software.

The ECM8 was specifically designed for electrochemical tests. When switch S1 is closed, the cell is connected to the Potentiostat. S1 switches all the signals required for 4-terminal electrochemical measurements, including the various signal shields and remote sense lines. This gives better noise immunity and virtually eliminates cable resistance effects.

Unlike general purpose multiplexers, the ECM8 is still in control of each cell when it is disconnected from the Potentiostat between measurements. Three different offline control modes are possible. With S3 and S4 open, the cell is maintained at open circuit. With S4 closed, the working and counter electrodes are shorted together, allowing electrochemical noise or galvanic corrosion experiments to continue.

With S3 closed, the ECM8 really distinguishes itself. Each ECM8 channel has its own independent local Potentiostat which can maintain the cell at constant polarization when the channel is offline. The D/A Converter of the local potentiostat can also be used as a direct analog output, useful for controlling ancillary apparatus such as rotators or temperature baths.

In addition, each channel of the ECM8 Multiplexer has an optional Auxiliary A/D Switch that can connect any one of eight connectors to one common point for additional experimental versatility.

Because of the flexibility of the ECM8 Multiplexer, it is possible to generate custom software scripts to employ the Multiplexer in unusual applications. For example, different experiments can be run on different channels. Or a sequence of two LPR curves followed by an EIS curve can be run for a specific number of cycles. There's virtually no limit to the possibilities.

A standard laboratory computer can control the ECM8 via an RS232 interface. All ECM8 commands are simple ASCII codes. This library, complete with source code, allows you to write a program for multiplexing cells with a nonGamry potentiostat. The ECM8 relays are rated for currents up to 1 ampere.

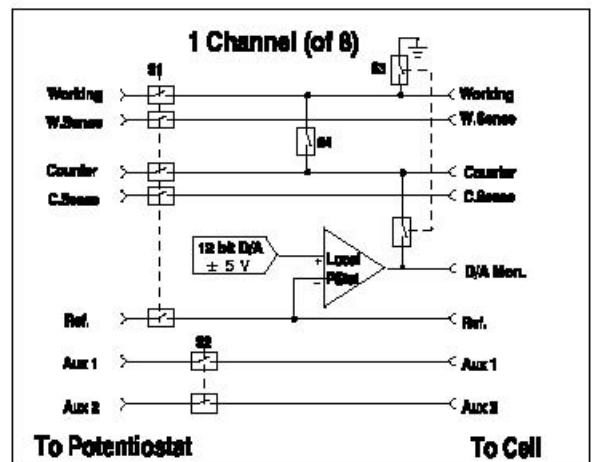

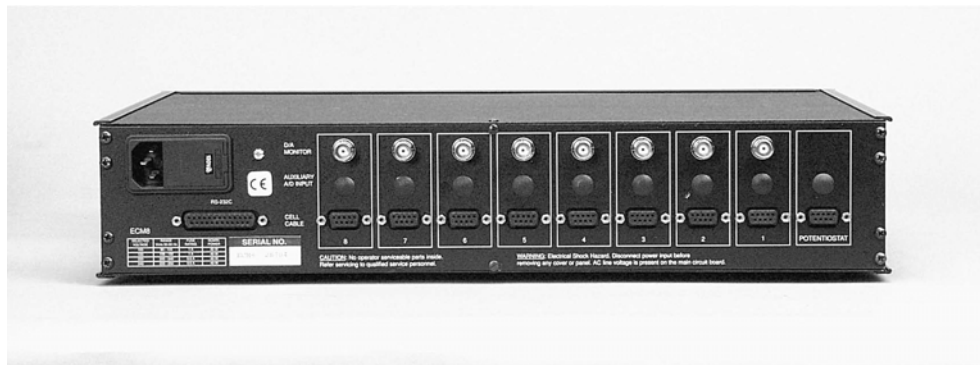

## Specifications

Modes	Active, Open, Shorted, Local
Channel Switching Time	<4 msec Excluding communication time
Cell Current	1 Amp max Switched
Input Voltage (operating)	±12 Volts vs. Chassis (except Counter)
Input Voltage (no damage)	±24 Volts vs. Chassis
Counter Electrode Voltage	±120 Volts vs. Chassis
Current Leakage	<2 nA max to any electrode in active channel from any source
Impedance	>500 MΩ <20 pF
Input Voltage Ranges	100, 120, 220, 240 V rms
Allowed Voltage Variation	±10% on each range
Power	<50 VA
Compliance - Current	±20 mA - 500Ω load
Compliance - Voltage	±11 Volts - 1kΩ load
Applied E Range	±5.12 Volts Working vs. Reference
Resolution	>80 dB (10 kHz) / >60 dB (1 MHz)
Zero Offset Error	<4 mV typical 0 Volts output / <10 mV max 10 kΩ load
Gain Error	<0.2% - 10 kΩ load
Reference Input Current	<50 pA
Note: Applied voltage error is the sum of zero offset and gain errors.	
Baud Rates	300, 600, 1200, 2400, 4800, 9600, 19200 Set via internal DIP switches
Default	9600 - Factory setting
Handshake	Hardware via RTS and CTS
Operating Temperature	0 to 45° C
Humidity	0 to 90% - Noncondensing

\*Specifications apply to the ECM8 at 25 °C, 116 VAC power, and operation with PCI4/300 Potentiostat/Galvanostat unless otherwise noted.

## Accessories

One 1.5 m cell cable (Gamry Part No. 98538) is provided. Auxiliary A/D Switch must be ordered separately. Also included are an Operator's Manual, an RS232 cable, and an ECM8 interconnecting cell cable. The interconnecting cable is compatible with the PCI4, the PC4, and the PC3 Potentiostats. Additional cell cables may be ordered separately. 1.5, 4.5, and 9 meter cables are available. Other cable lengths may be special ordered.

## System Information

The ECM8 Multiplexer is protected by a limited 2 year factory service warranty. Gamry Instruments offers selected multiplexed electrochemical measurement systems for the ECM8. The DC105□ and EIS300□ software packages support the ECM8 with builtin multiplexed scripts. Contact Gamry for the specific multiplexed experiment in which you have interest. Custom scripts for the ECM8 are available.

ECM8 Rev 6.0 3/2/04 - Copyright 1990-2016 Gamry Instruments. All specifications subject to change without notice.



734 Louis Drive Warminster, PA 18974 +2156829330 Fax: +2156829331 info@gamry.com www.gamry.com